

Syncro View Marine

Marine & Offshore Local LCD Control Panel Repeater

Features

- Up to 15 annunciators can be connected to each Syncro ASM fire control panel.
- Large liquid crystal display (240 x 64 pixels)
- High brightness LED indications
- Internal sounder
- Replicates all Syncro ASM panel controls
- Simple, two-wire serial connection
- Small, Syncro style enclosure
- Removable electronics for easy installation
- 24V DC or 230V AC power options
- Low power consumption
- Multi language options
- Connection monitored by Syncro ASM control panel

Product Overview

- Designed and manufactured to the highest standards in a quality controlled environment the Syncro VIEW Marine fire alarm annunciator provides a simple and convenient method of extending the controls and indications of the Syncro ASM fire alarm control panel to other locations.
- The large, graphic liquid crystal display and high brightness LED indicators duplicate the indications on the Syncro ASM fire alarm control panel at up to 15 additional locations via a simple, two-wire serial data connection.
- The Syncro VIEW Marine is available in either a 24V DC powered option (which can be powered via an additional 2 cores from the Syncro ASM control panel, a maximum of 4 VIEW Marine Repeater Panels in this combination) or up to 15 VIEW Marine Repeater Panels if powered local from an ancillary 24V DC supply or a 230V powered option with local battery back up.
- Syncro VIEW Marine is housed in a small enclosure which is styled similarly to the Syncro ASM control panel and is ideal for installations where a large fire control panel would be detrimental to décor or where space is at a premium such as the Control Bridge or Helm.
- Up to 15 Syncro VIEW Marine annunciators can be connected to each control panel on the Syncro ASM network making VIEW Marine ideal where multiple points of indication and/or control are required in such as places as Engine Rooms, Staff Quarters, Living Spaces or Control Area's.



Model No. MK67000AM1



Model No. MK67750M1

Equipment

Product Code	Description	PSU	Size (mm)
MK67000M1	Syncro View Marine repeater panel	-	330 x 255 x 90
MK67750M1	Syncro View Marine repeater panel	750mA	330 x 255 x 90
MK67001M1	Syncro View Marine repeater panel c/w enable keyswitch	-	330 x 255 x 90
MK67751M1	Syncro View Marine repeater panel c/w enable keyswitch	750mA	330 x 255 x 90
MK67000AM1	Syncro View Marine repeater panel (24v Model Flat Plate Fascia, Space saving Model)	-	see drawing below
MK67001AM1	Syncro View Marine repeater panel (c/w enable keyswitch - 24v Model Flat Plate Fascia, Space saving Model)	-	see drawing below

Semi-flush versions are available to order

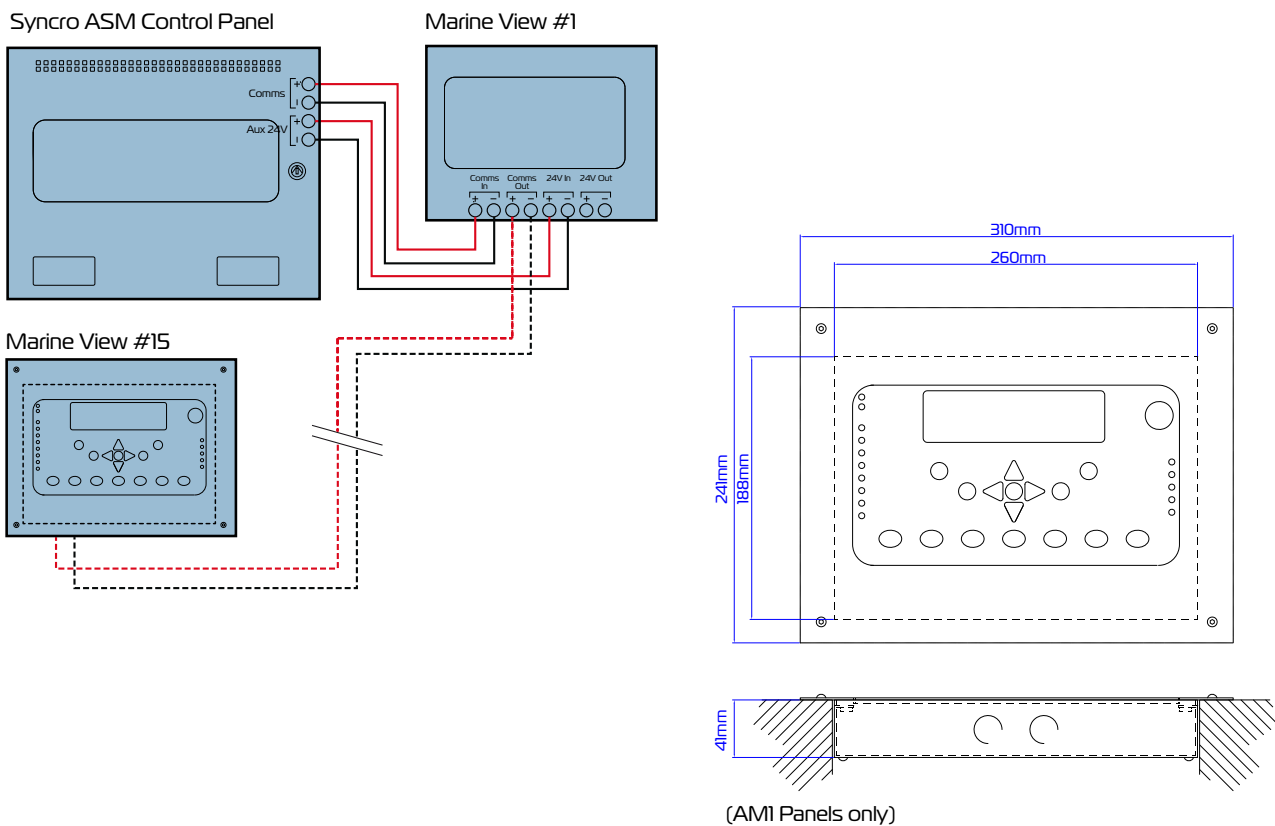

Technical

Construction	- 1.2mm Mild steel
IP Rating	- IP30
Cable entry	- 5 x 20mm knockouts in top of box and 5 in rear
Finish	- Epoxy powder coated
Colour - lid & box	- BS 00 A 05 grey - fine texture
Colour - controls plate & labels	- Ral 7047 light grey - satin
Display	- 8 lines of 40 characters graphic LCD
Mains supply (Mains models only)	- 230V AC +10% - 15% (20 Watts maximum)
24V supply (24V DC models only)	- 21 to 30V DC
Mains supply fuse	- 2 Amp, 20mm
Power supply rating	- 28V 750mA total (including battery charging)
Maximum ripple current	- 200 millivolts
Battery type (Yuasa NP)	- Two 12 Volt 1.9Ah sealed lead acid in series
Battery charge voltage	- 27.6VDC nominal
Battery charge current	- 200mA maximum
Battery fuse	- 200mA, 20mm, glass
Maximum current draw from batteries	- 95mA
Quiescent current of panel in mains fail	- 0.03 Amps
Serial data connection	- 2 core RS485 (Up to 1200 metres total cable length)
Maximum terminal capacity	- 2.5mm ²